

# 車種多様 / 大型トラックデッキ自動圧入&搬送ライン

## 1工程: テッキ供給/PIN圧入



## 2工程: 自動搬送/ROBOT増し打ち





# 飲料水パッケージ種別搬送ライン

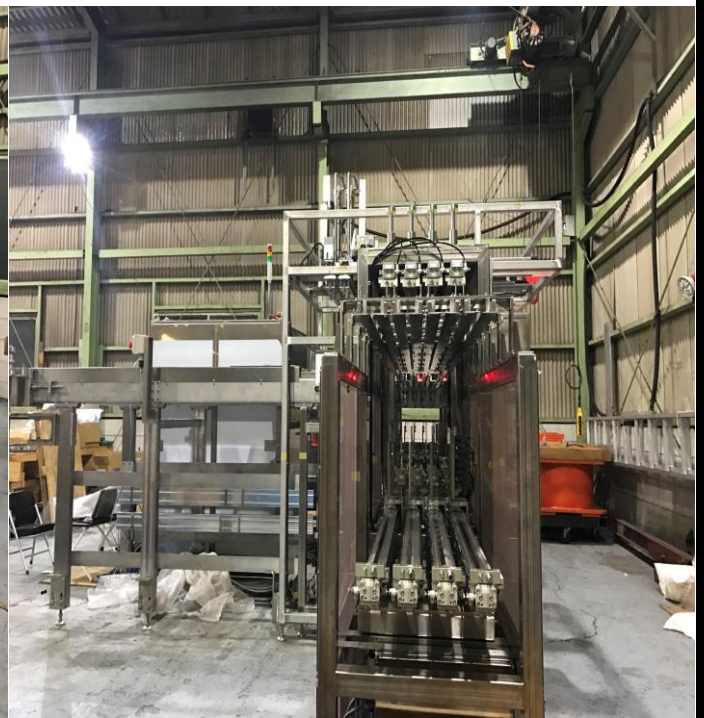



## 5種類/LNGタンク自動圧入&溶接ライン

**1工程:供給/仮付け(TIG溶接)**  
**自動圧入後、溶接位置のレーザー検出**



**2工程:自動搬送/本付け(MIG溶接)**  
**溶接位置のレーザー全周検出**



# 各種 / 治具 & ROBOTセル

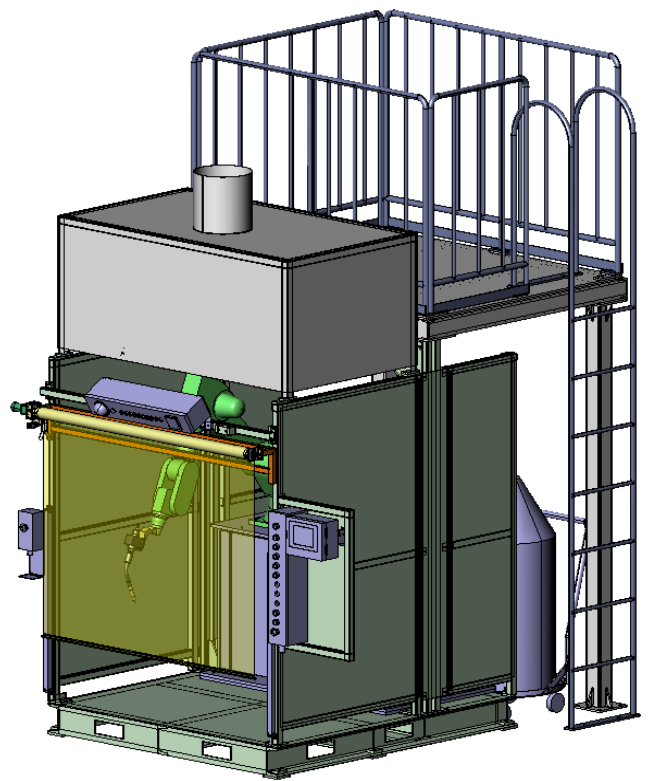
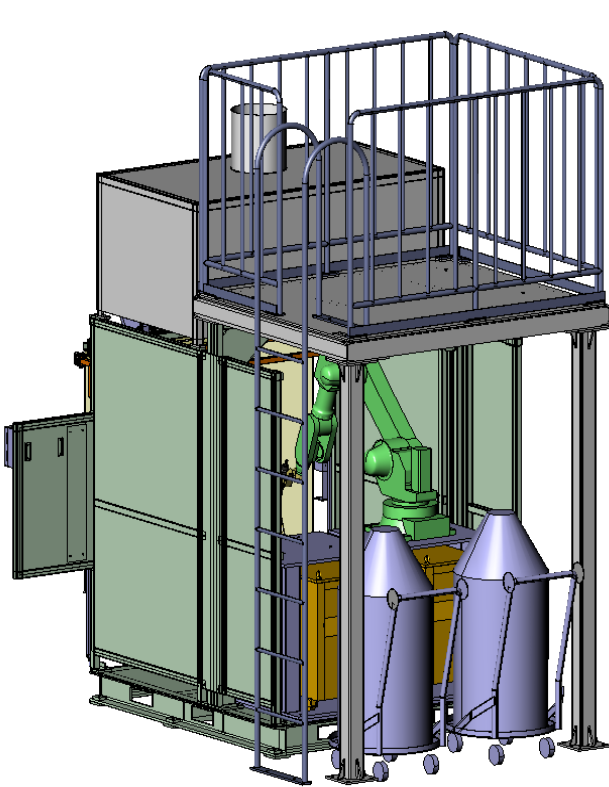
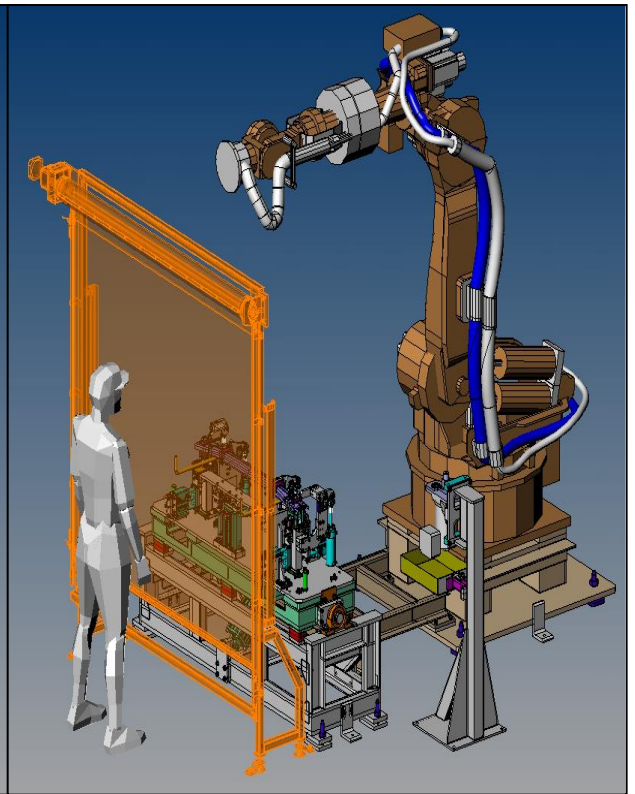
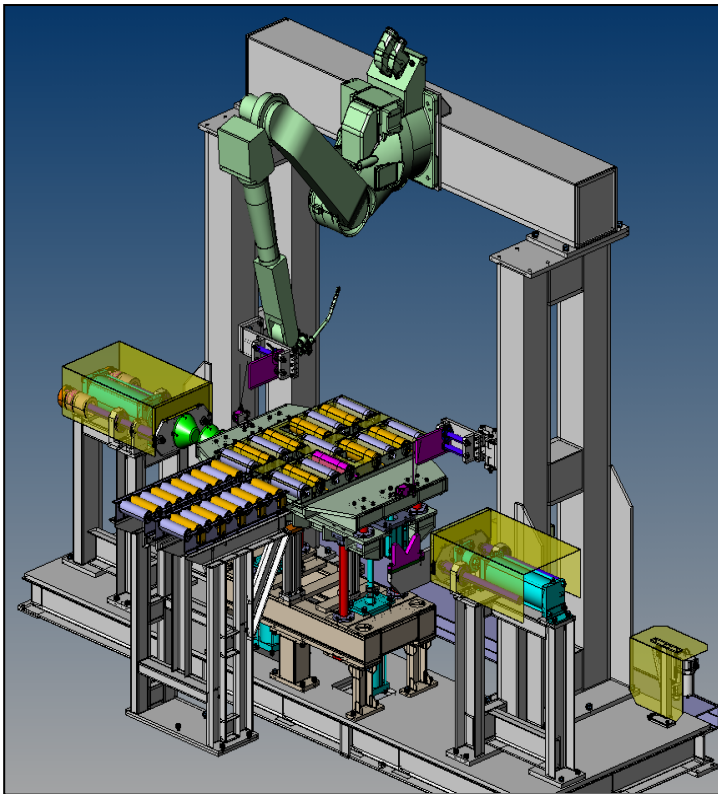



# スポット溶接治具

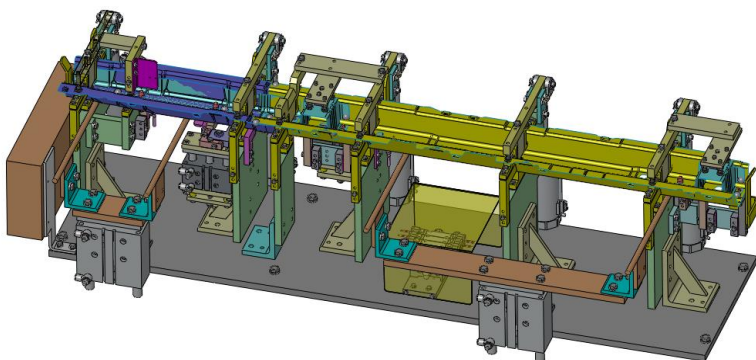
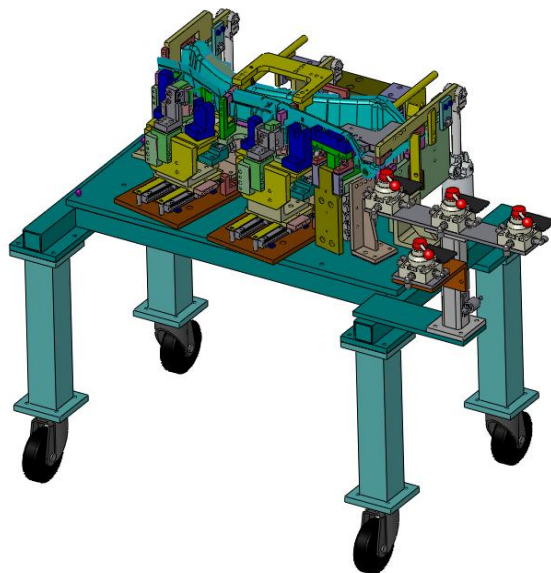
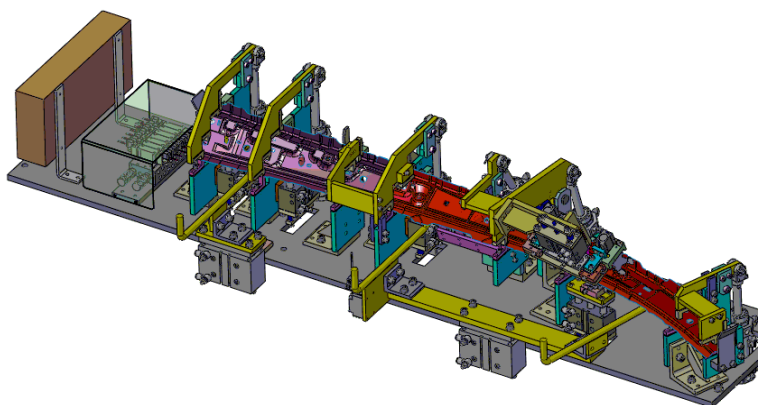
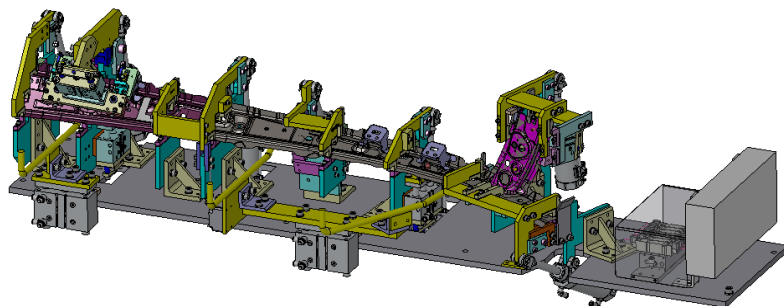

# 車種段替え式 / BUSH自動圧入 & 画像検査 & 搬送ライン

## 1工程：治具段替え式 / BUSH圧入



## 2工程：カメラ画像認識式 / 検査工程

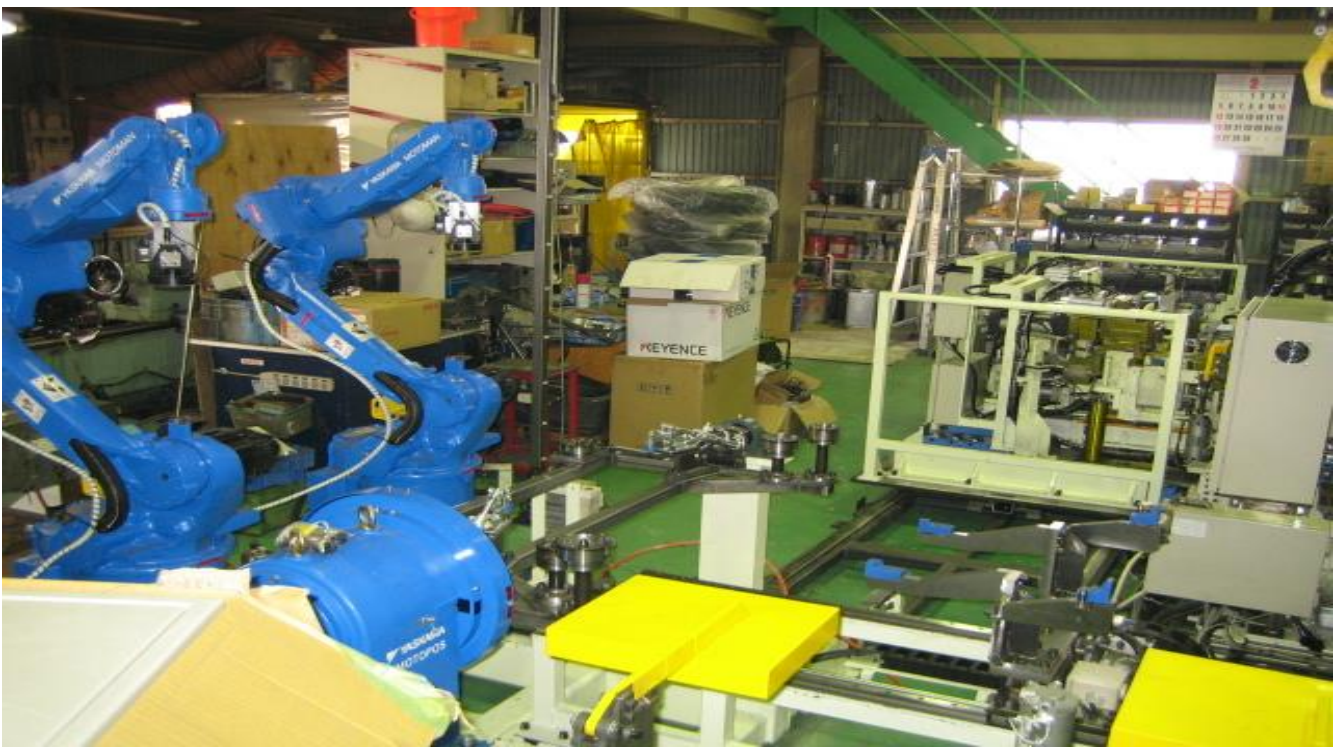



# パレット搬送装置

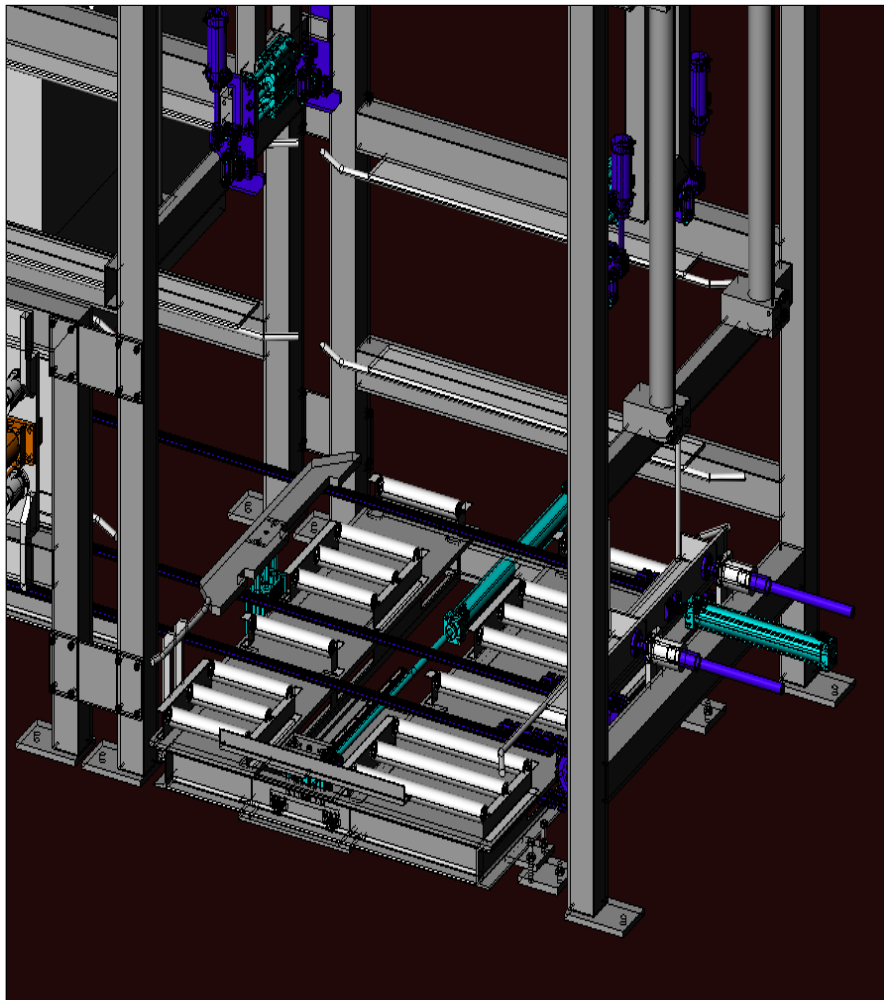
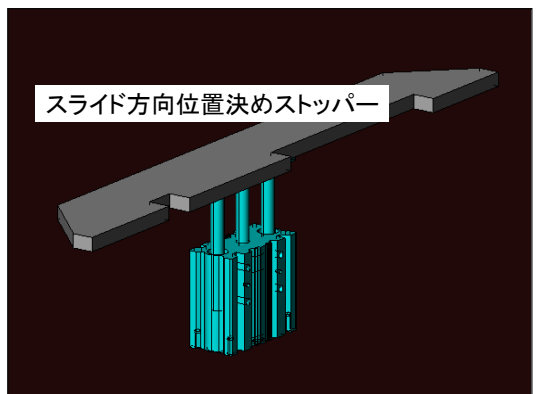
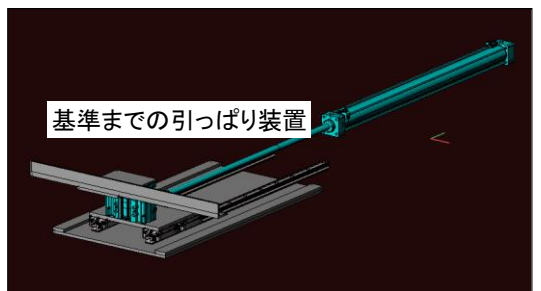
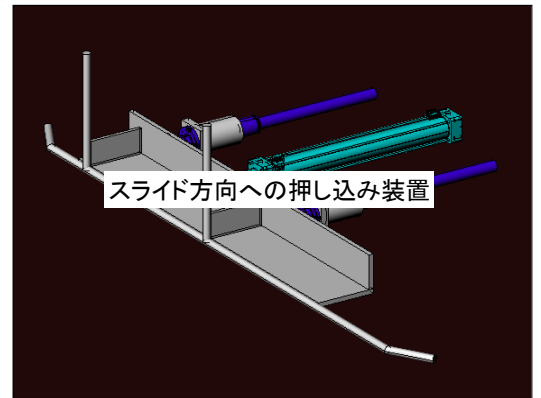
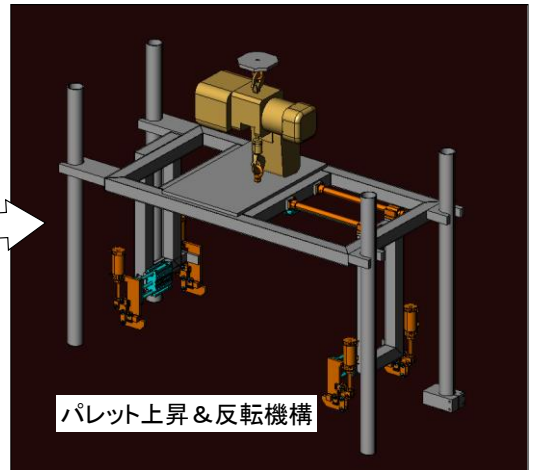
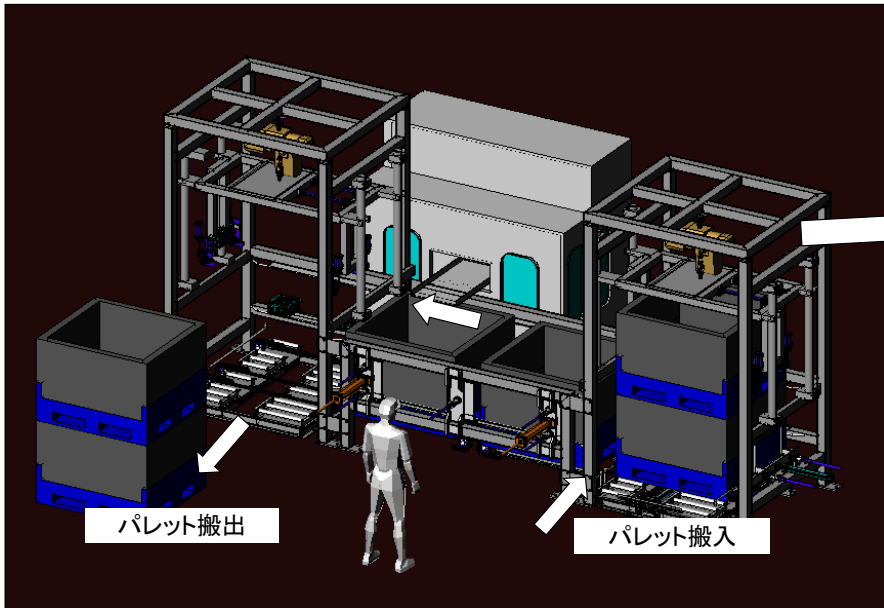

# スポット溶接

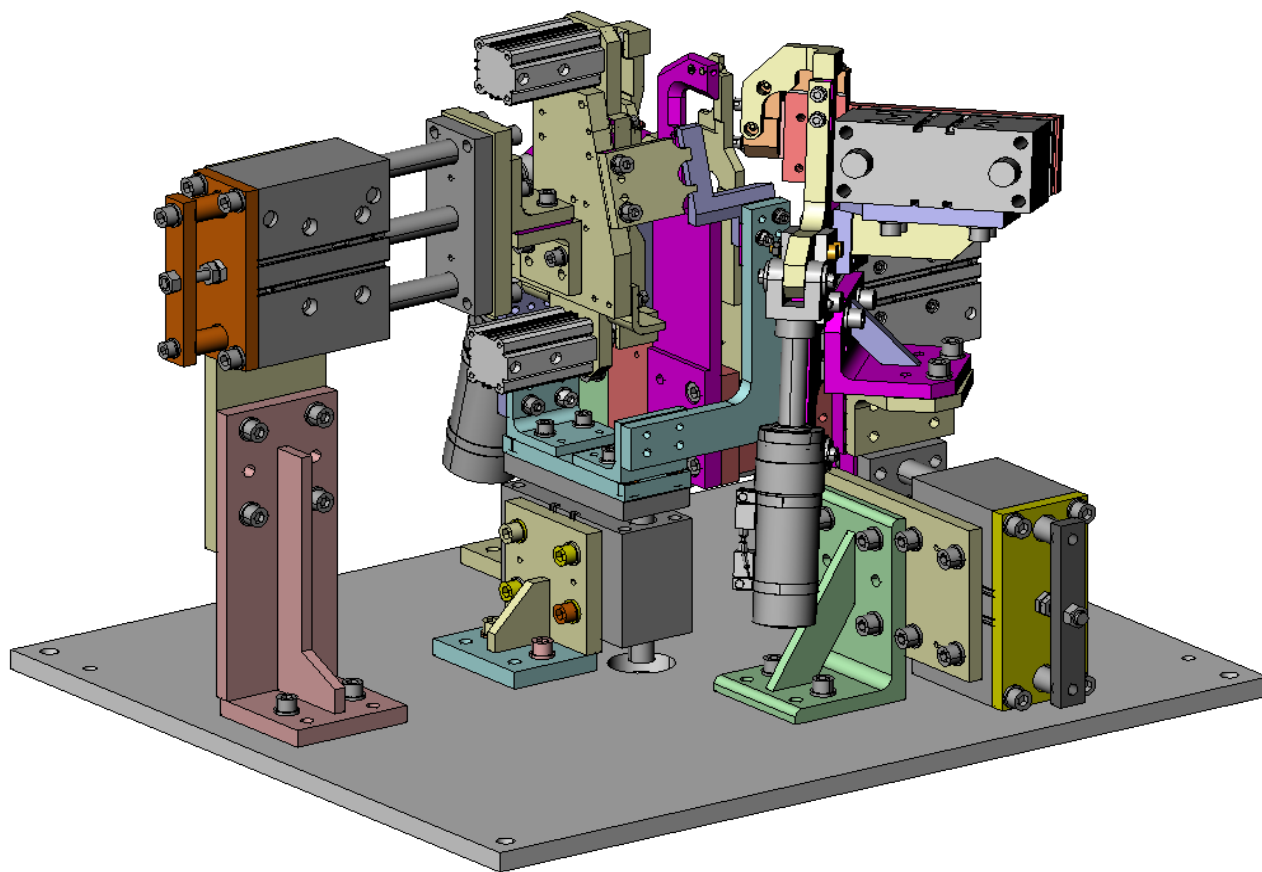
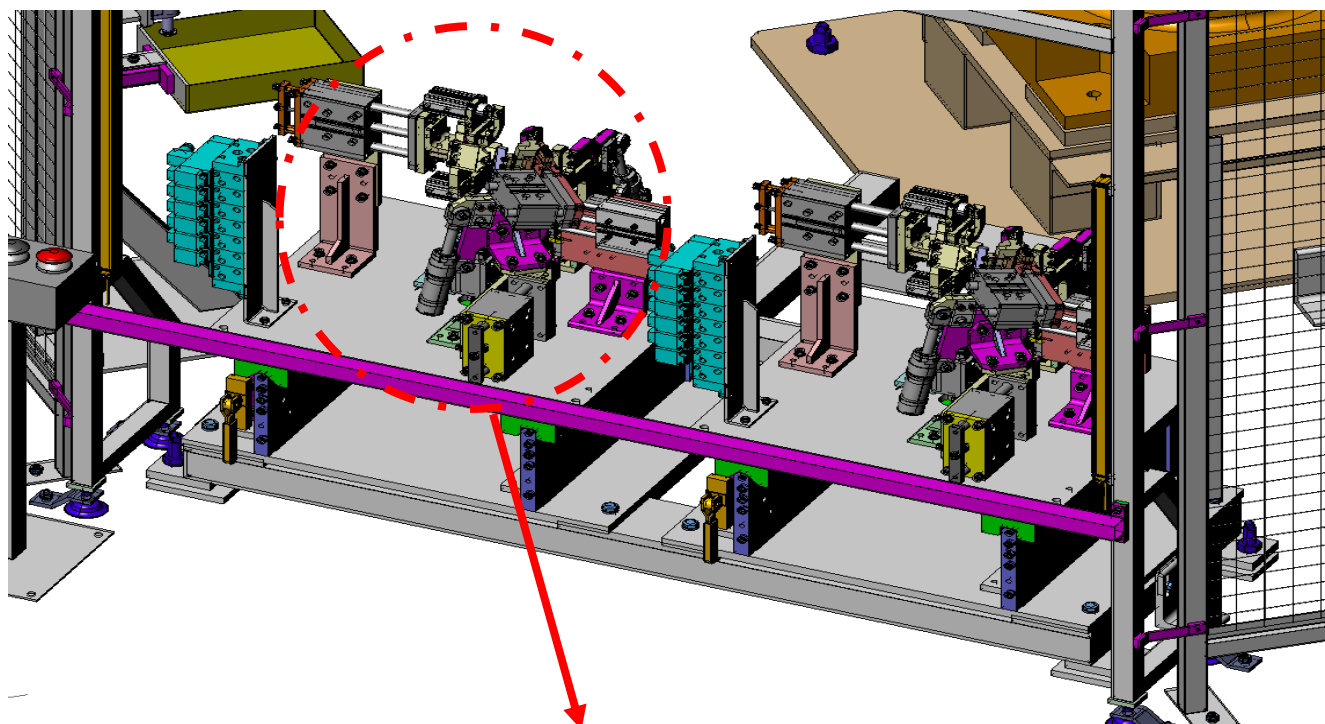



# スポット溶接

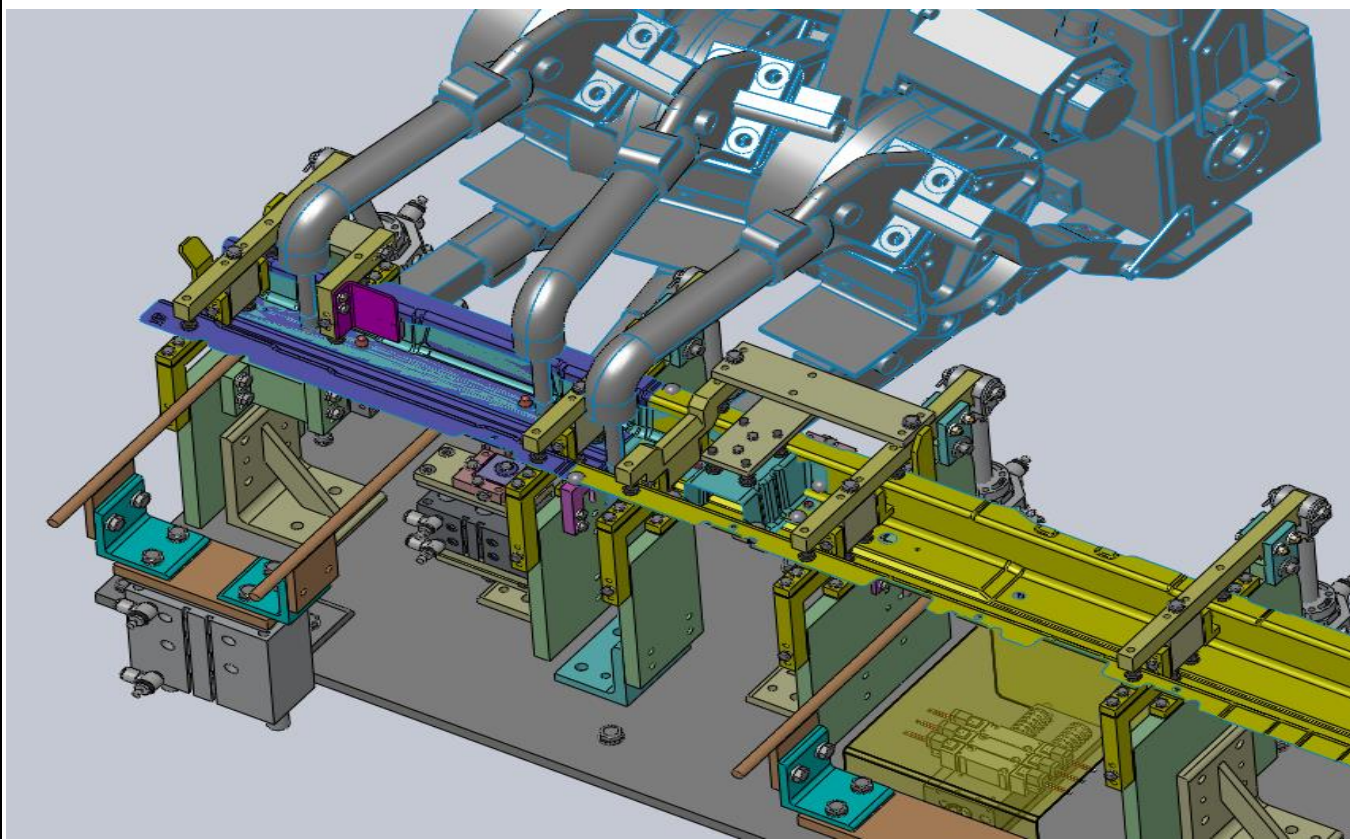
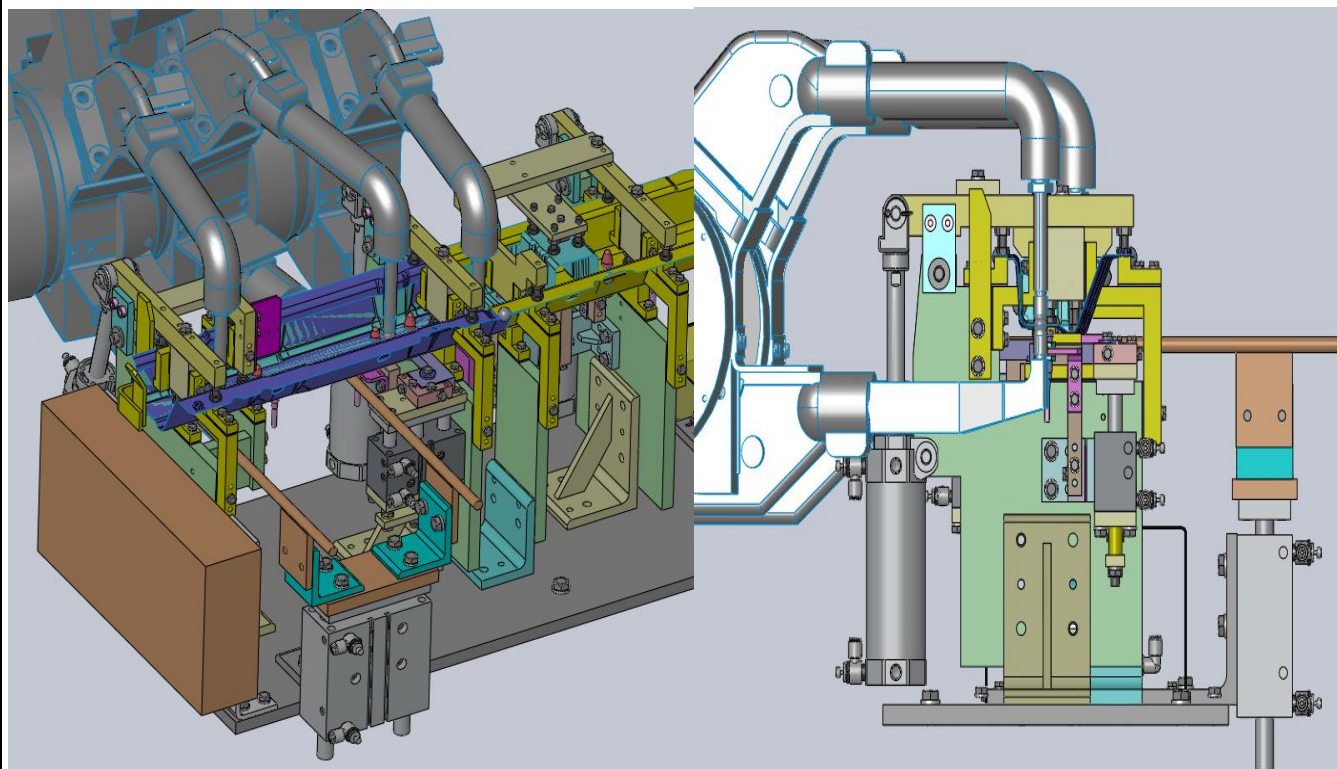



# リーマ加工機

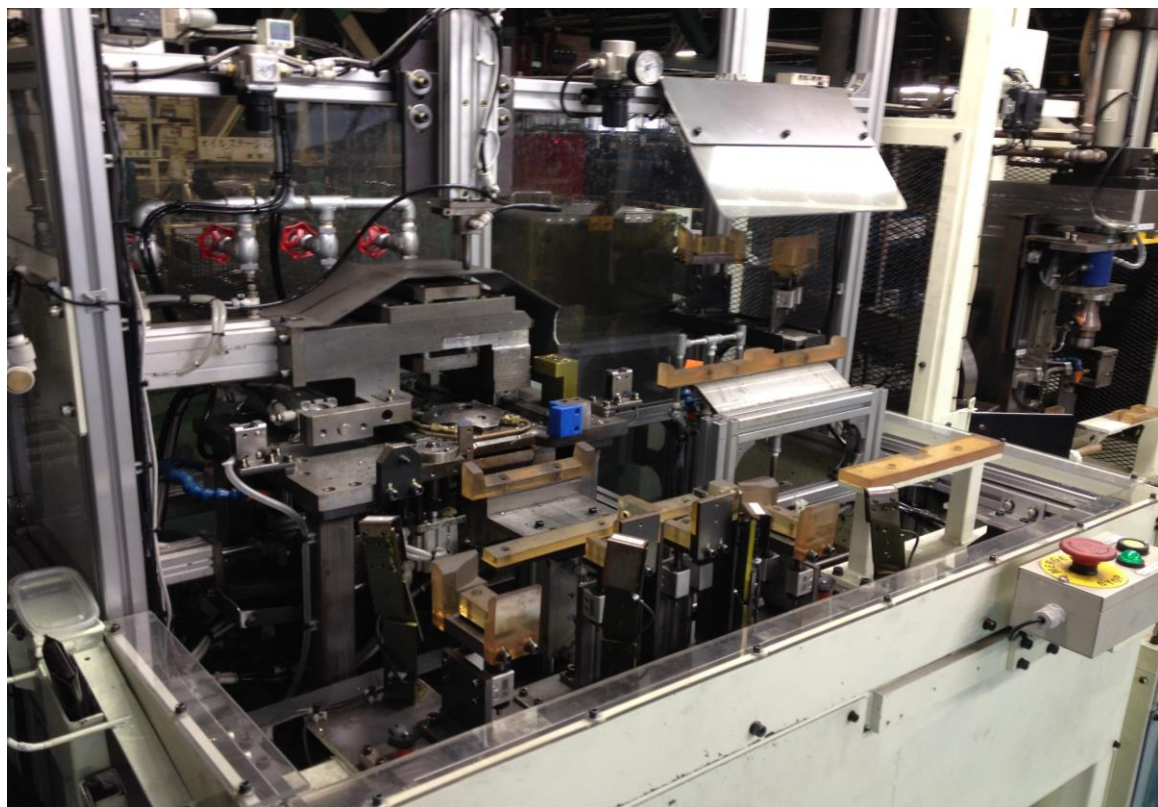
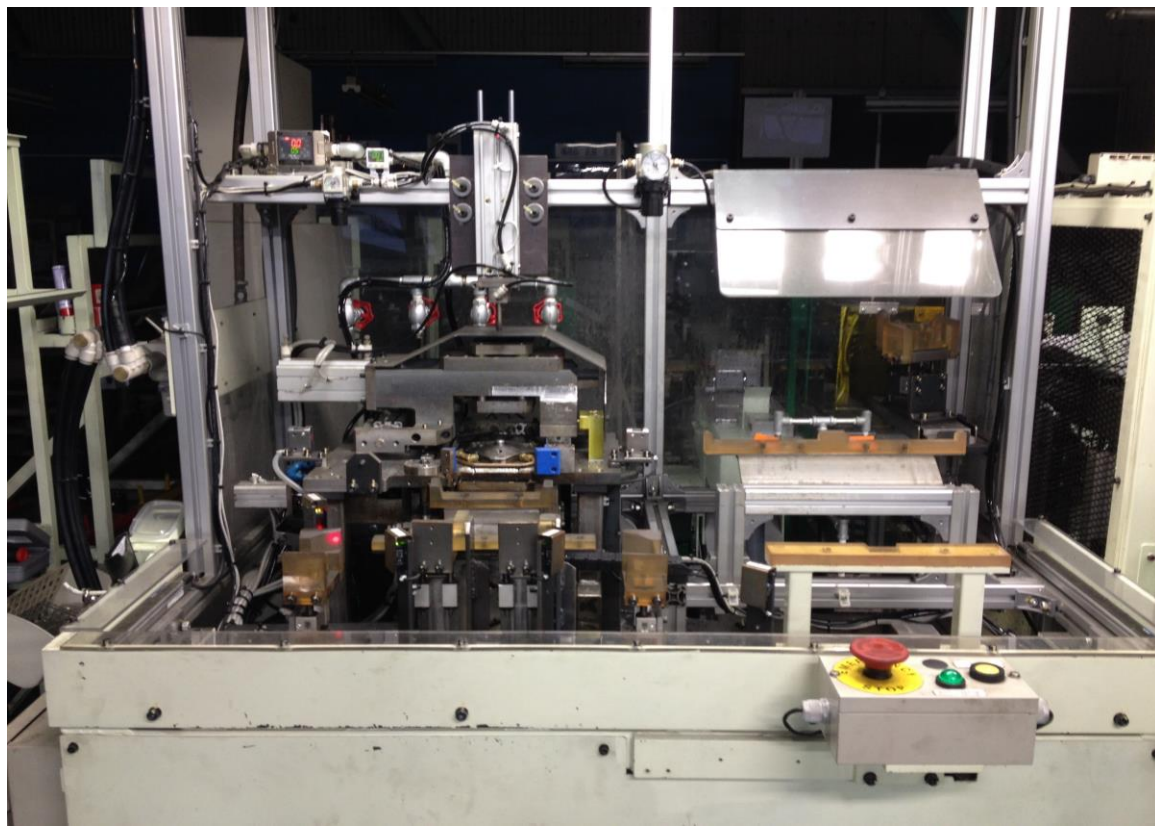



# 段替え式/車載シート溶接治具

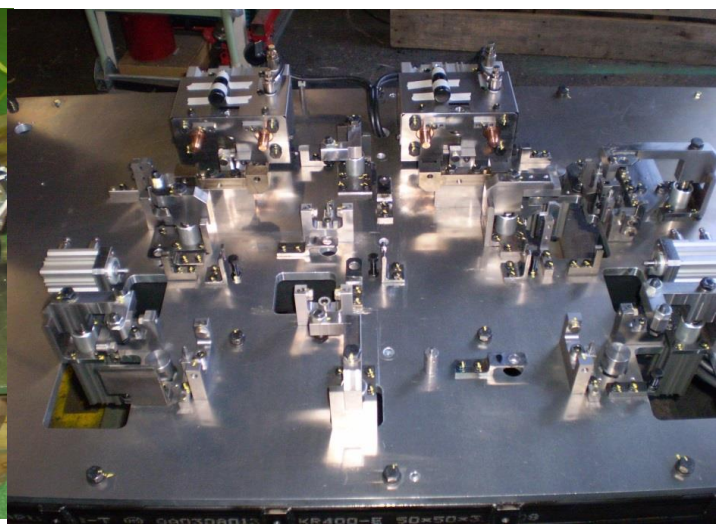
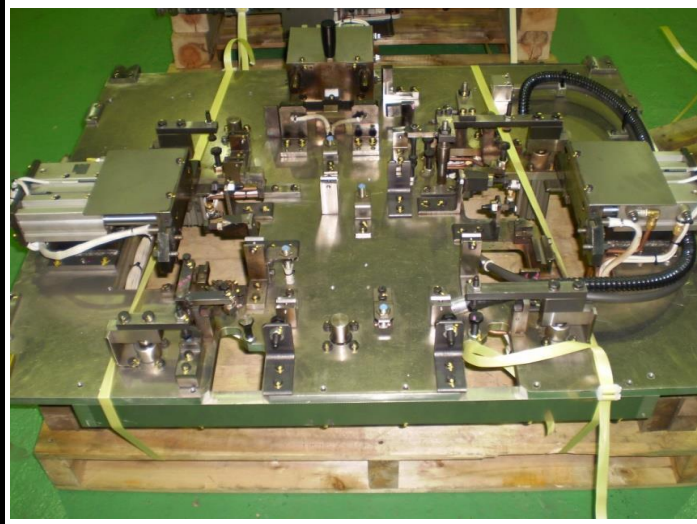
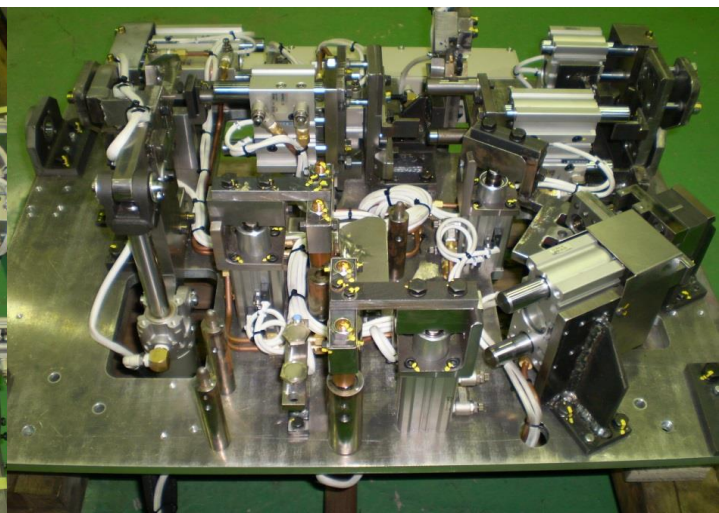
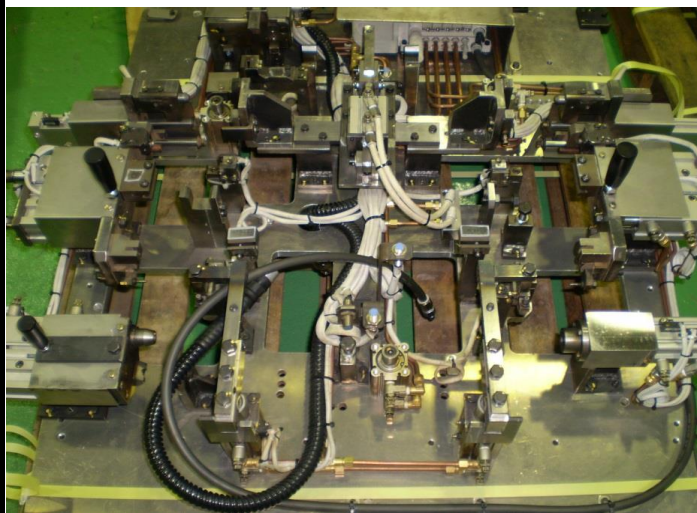
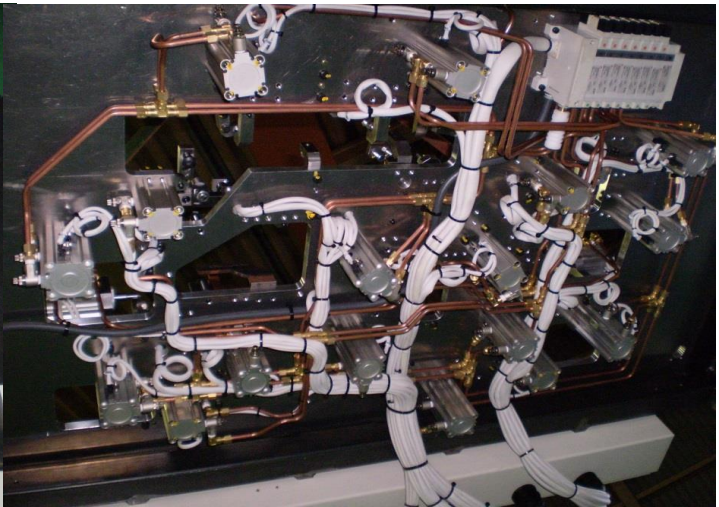
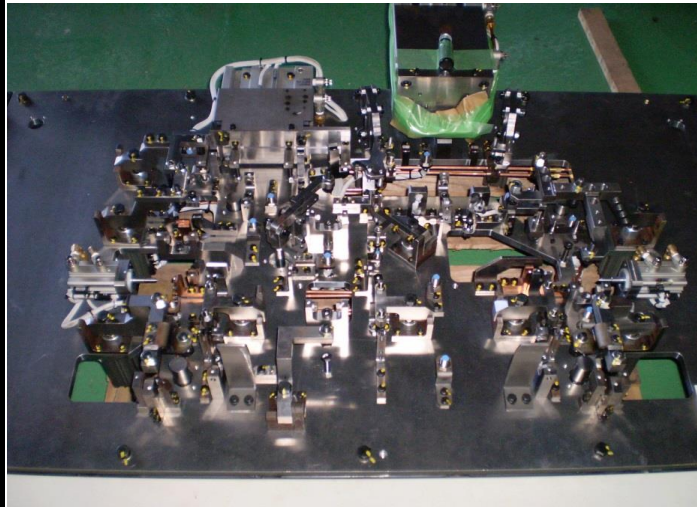



# 段替え式/車載シート 溶接治具

Perspective

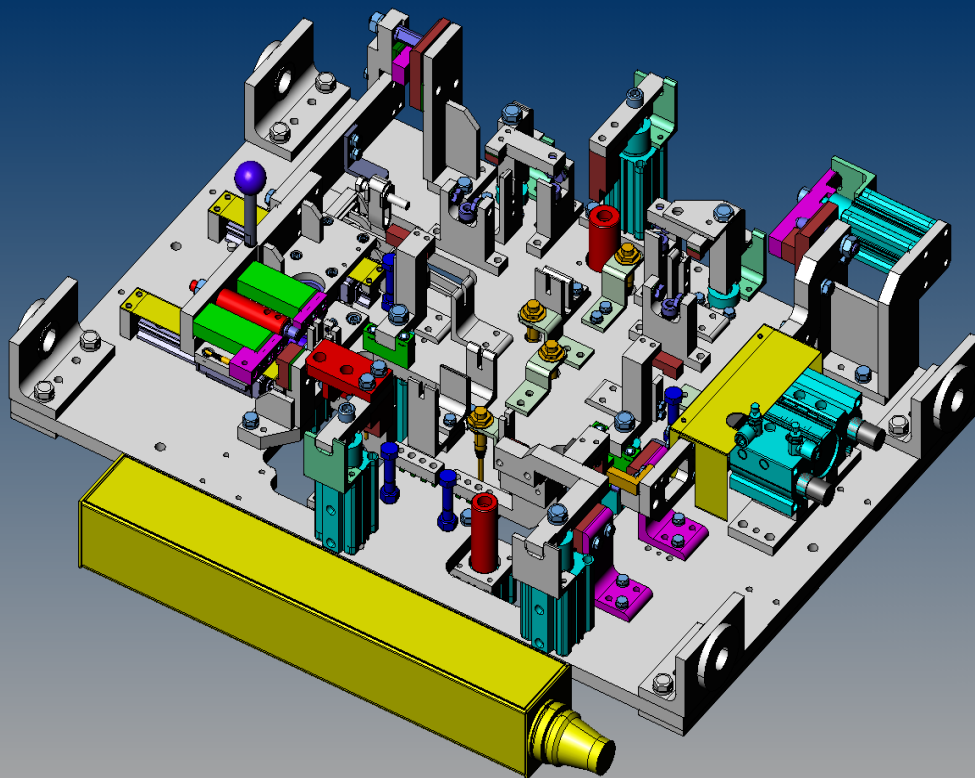

Perspective

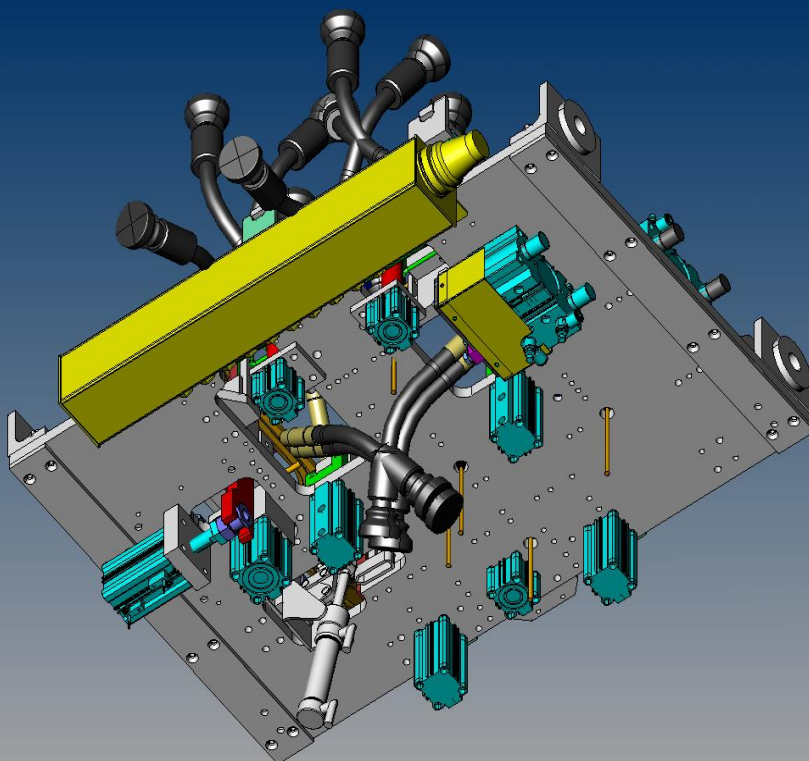



# 自動グリス塗布装置

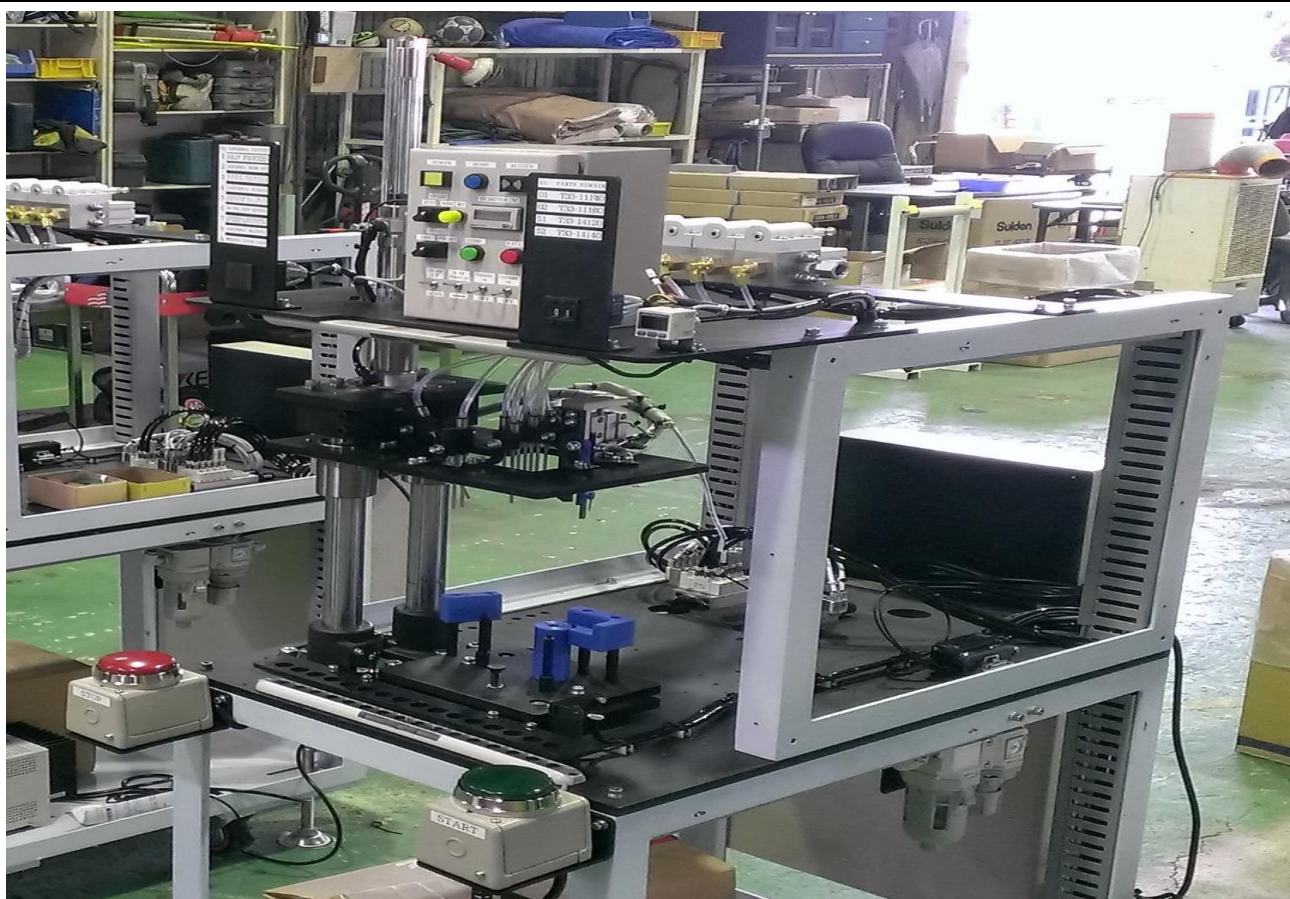



# 自動供給(向き判別) / BUSH 圧入装置

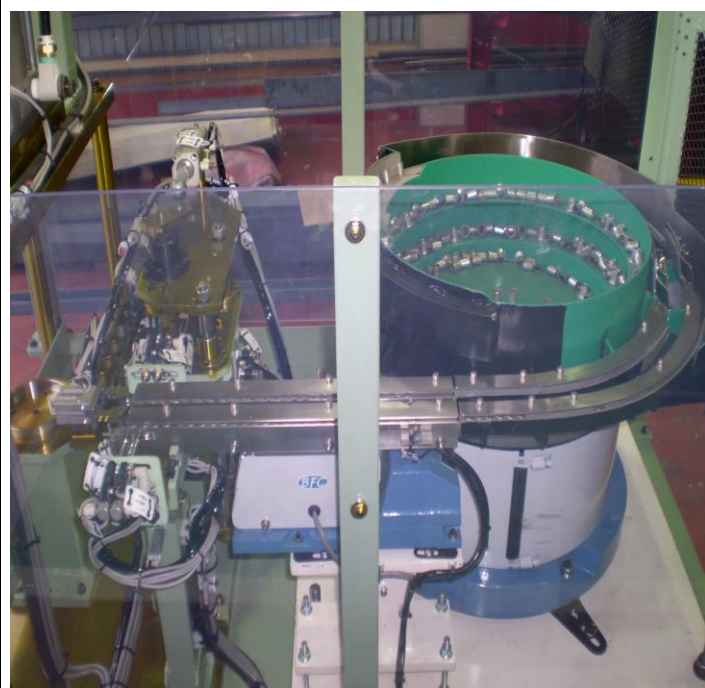
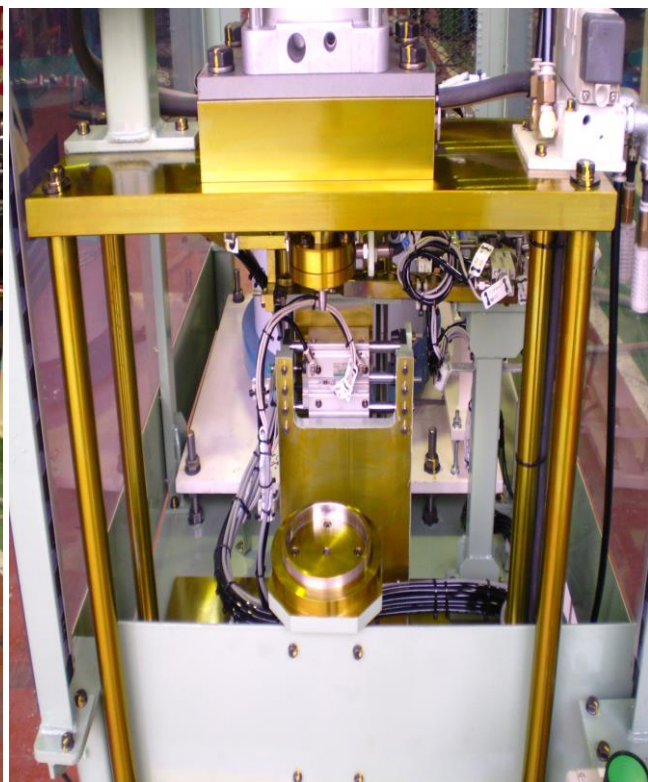
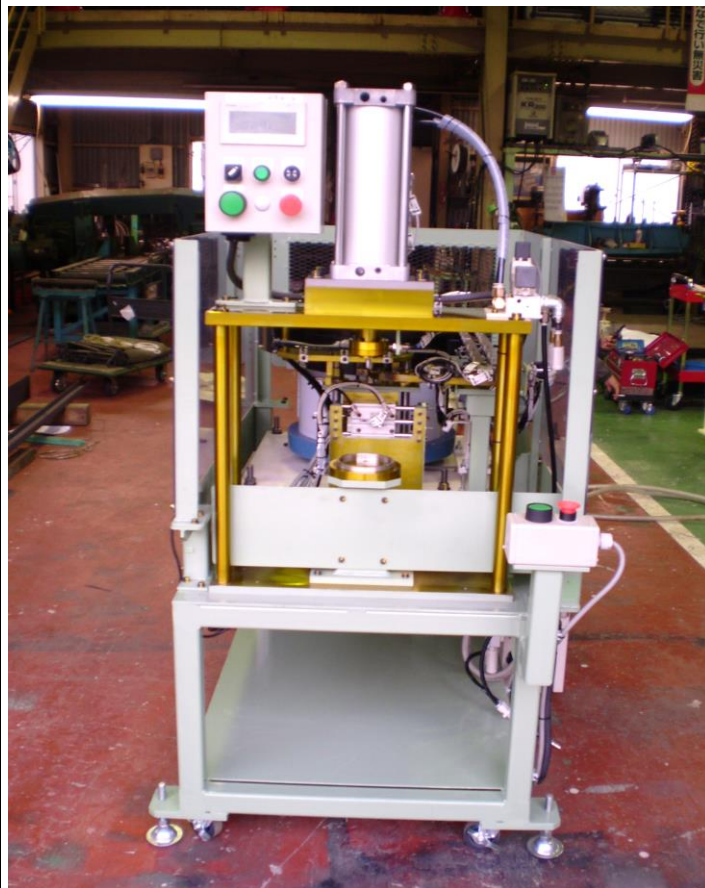



# 自動/圧入 & ナットランナー機

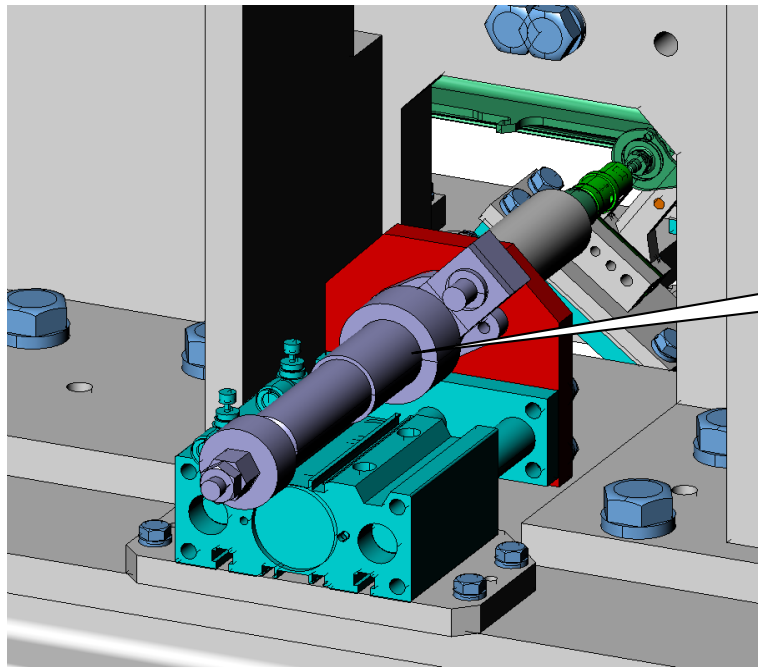

ナットランナーにて自動締結

ロードセル/側長器にて圧力及び圧入量の管理

